

ACCESSORY SETUP INSTRUCTION

WINDSHIELD ASSY -- PN: 9DSV-805100-6000

VALID FOR: MY2020 and Newer CFORCE 600

BEFORE YOU BEGIN: Read and understand the instructions before starting any work. Make sure that all parts are ready and that you have all the tools required for assembly.

NOTE: CFMOTO shall not be liable for any damage caused by incorrect assembly. CFMOTO recommends that all original accessories be assembled by an authorized CFMOTO dealer.

Before assembly, park the vehicle on a flat surface, put the transmission gear into Park (P) and turn off the key switch.

Zhejiang CFMOTO Power Co., Ltd. All rights reserved. Reproduction of this document, even in part, as well as copying of all kinds, is permitted only with the express written permission of the copyright owner.

MEANING OF SYMBOLS

 - Indicates information with more details or tips.

 - Indicates information of warning or danger.

PARTS LIST:

ITEM	PART NAME	PART NUMBER	QTY.	REMARK
1	WINDSHIELD ASSY	9DSV-805100-6000	1	For structure reference only
2	FRONT WINDSHIELD	9DQV-805205-3000	1	
3	LH WINDSHIELD BRACKET	9DSV-805101-6000	1	
4	RH WINDSHIELD BRACKET	9DSV-805102-6000	1	
5	RUBBER BUSHING	6KJ0-120004	4	
6	SCREW M6x22	30102-060022870	4	
7	RUBBER SLEEVE LINER, FRONT LICENSE BRACKET	5020-031002	4	
8	NUT	30206-060570	4	
9	INNER HEX SCREW M8x50	30102-080050870	4	

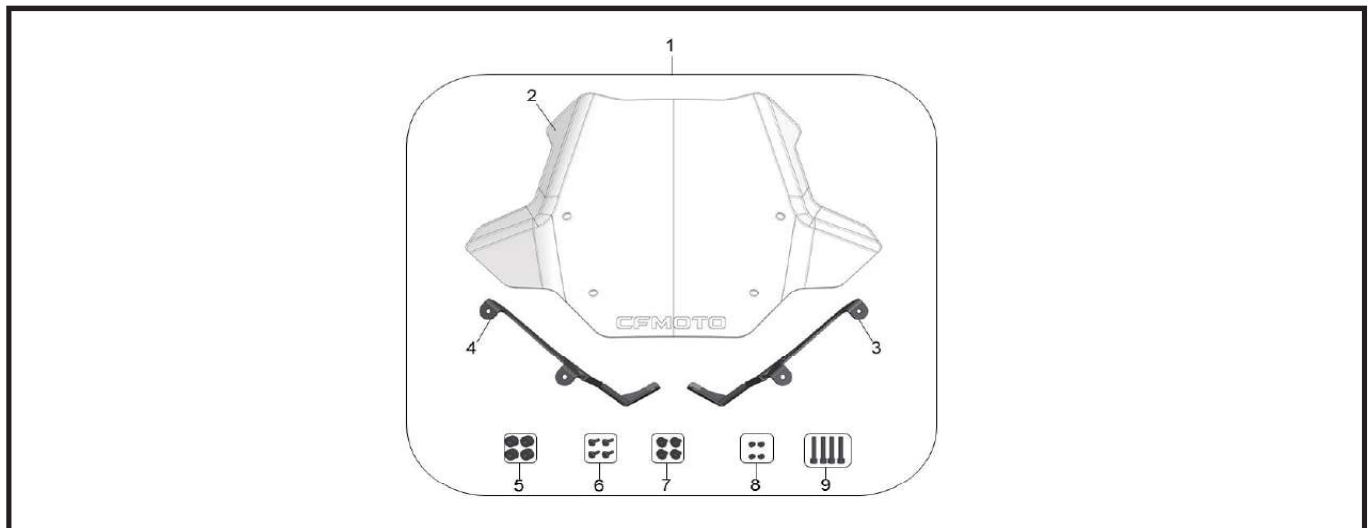

TOOL LIST:

ITEM	DESCRIPTION	QTY.	REMARK
1	PROTECTIVE GLOVES	1	Recommended Tools
2	10mm WRENCH	1	
3	4mm ALLEN WRENCH	1	
4	6mm ALLEN WRENCH	1	

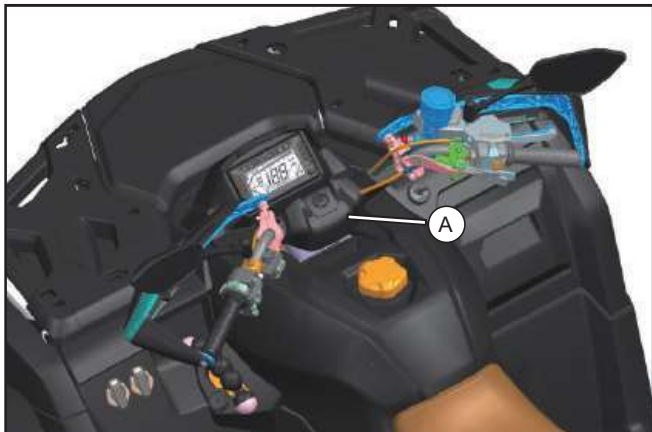
ASSEMBLY AND INSTALLATION

// Pull up and remove the handlebar guard (A).

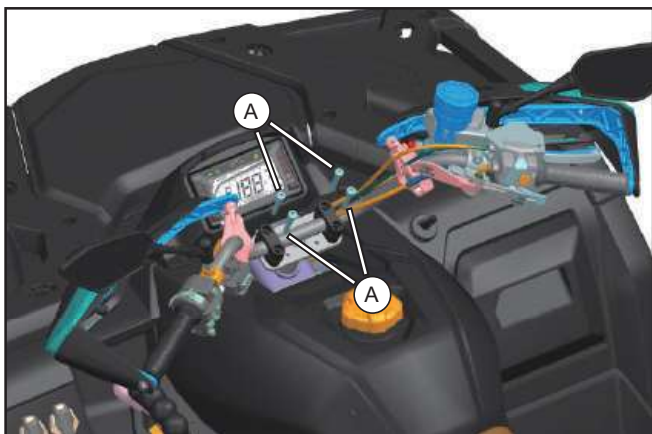

// Remove the four handlebar clamp screws (A).

NOTE: These screws will not be reused.

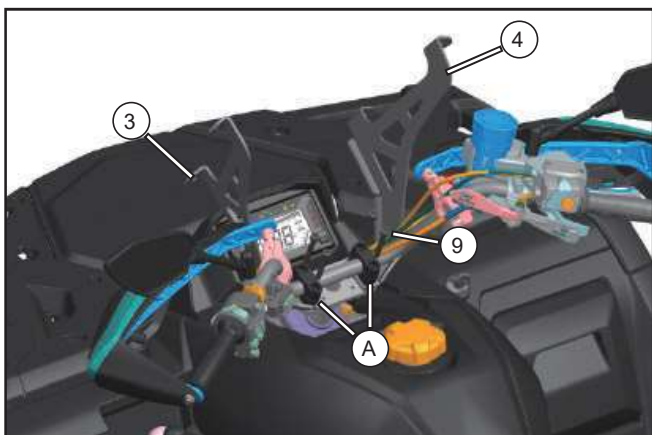

// Place the LH & RH windshield bracket (3 & 4) under the handlebar clamp blocks (A) as shown, align the thread holes, then install and torque the M8x50 screws (9) to specification.

NOTE: When possible, do not disturb the handlebar clamp block positions for easier reassembly. Realign the handlebar position as necessary and tighten the screws to the proper torque specification.

INNER HEX SCREW	M8x50	30102-080050870	20-30N.m
-----------------	-------	-----------------	----------

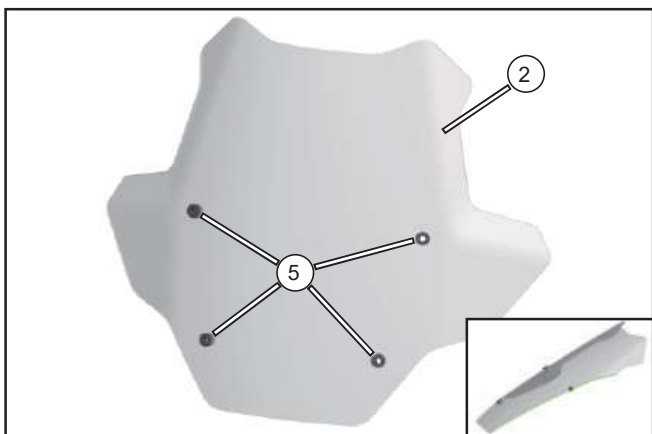

// Install the rubber bushings (5) into the corresponding holes on the front windshield (2).

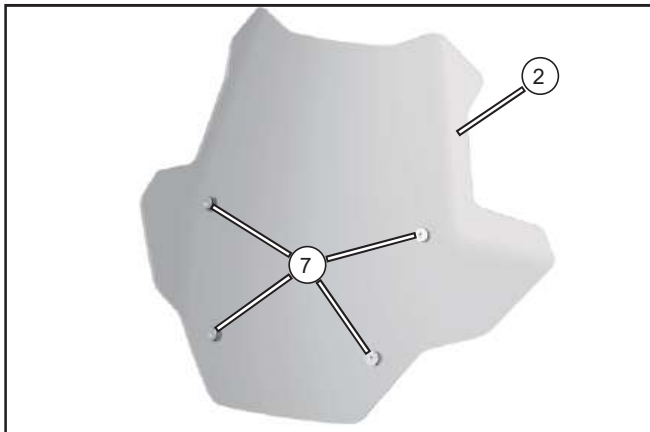
ASSEMBLY AND INSTALLATION

// Install rubber sleeve liners (7) into the corresponding rubber bushing holes on the front windshield (2).

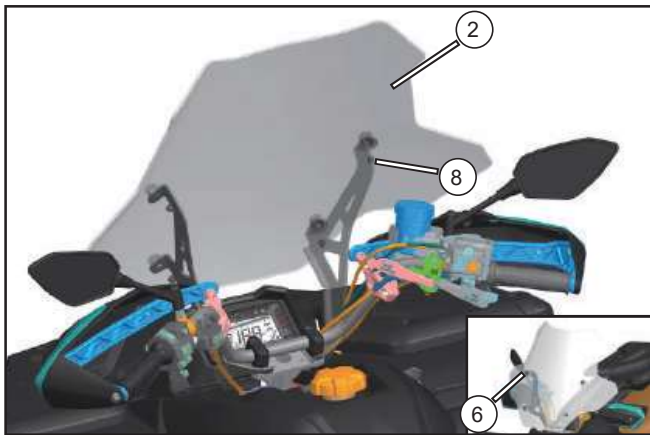

// Align the holes on the front windshield (2) to the windshield brackets, then install the supplied M6x22 screws (6) and nuts (8). Tighten the fasteners sufficiently, using caution not to over-tighten.



// Reinstall the handlebar guard (A).



// The windshield assembly is complete.